

System Design for Fan Convectors

Fan convectors are intended to be connected to central heating systems in the same way as radiators, and offer advantages and benefits not available from traditional emitters. To ensure optimum fan convector performance, great care must be taken to ensure that the choice of unit and the heating system design are considered. The following factors must be taken into consideration:

- Fan convectors should only be used on closed circulation, two pipe, pump assisted central heating systems.
- Fan convectors should be correctly sized to match the heat loss requirement of the room with the unit operating at its lowest fan speed.
- The heating system must be capable of providing sufficient hot water through the heat exchanger. This means that:
 - The minimum pipe size should be 15mm.
 - Fan convectors are not suitable for use on microbore pipe-work.
 - Fan convectors are not suitable for one-pipe systems.
 - Where the unit is fitted onto a system with other emitters, a separate circuit for the fan convector should be considered to ensure an adequate water flow through it.
- The heating system water temperature must be greater than 43°C in heating mode for the unit to operate (lower temperatures possible for heat pump applications).
- Optimum performance of the fan convector will require effective balancing of the whole system.
- Fan convectors should not be used to replace radiators in existing systems unless pipe-work sizing, system design and system balancing can guarantee an adequate flow of water through the fan convector.
- The maximum working pressure through the heat exchanger is 10 bar (150 lb/in²). The maximum allowable water temperature through the heat exchanger is 90°C.
- The unit should be mounted on a flat wall, and stud or partition walls should be avoided to minimise the possibility of noise transmission.

KICKSPACE® Product Range

Hydronic Product Range

Model	Flexible Hoses*	Isolating Valves (15mm)	Electric Cable	Transformer	Fan Only Option
KICKSPACE® 500	Supplied	Supplied	2 metres (mains fitted)	N/A	Yes
KICKSPACE® 600	Supplied	Supplied	2 metres (mains fitted)	N/A	Yes
KICKSPACE® 800	Supplied	Supplied	2 metres (mains fitted)	N/A	Yes
KICKSPACE® Floor	Supplied	Supplied	2 metres (mains fitted)	N/A	Yes

Low Voltage Hydronic Product Range

Model	Flexible Hoses*	Isolating Valves (15mm)	Electric Cable	Transformer	Fan Only Option
KICKSPACE® 600-12V Compact	Supplied	Supplied	3 metres (low voltage fitted) 2 metres (mains fitted)	Supplied (external from product)	Yes
KICKSPACE® 600-12V	Supplied	Supplied	3 metres (low voltage fitted) 2 metres (mains fitted)	Supplied (external from product)	Yes

Duo (Hydronic-Electric) Product Range

Model	Flexible Hoses*	Isolating Valves (15mm)	Electric Cable	Transformer	Fan Only Option
KICKSPACE® 500 Duo	Supplied	Supplied	2 metres (mains fitted)	N/A	Yes

Electric Product Range

Model	Flexible Hoses*	Isolating Valves (15mm)	Electric Cable	Transformer	Fan Only Option
KICKSPACE® 500E	N/A	N/A	2 metres (mains fitted)	N/A	Yes
KICKSPACE® 600E	N/A	N/A	2 1/2 metres (mains fitted)	N/A	Yes

*750mm x 10mm bore, EPDM hoses, sheathed in AISI 304 stainless steel braid.

Please note that KICKSPACE® 600E grilles are an integral part of the product and can not be changed.

KICKSPACE® Controls

Hydronic (KICKSPACE® 500, 600, 800, 600-12V & 600-12V Compact)

Fan Speed - Normal/off/boost.

Summer/Winter - Fan only/heating option.

Hydronic Electric (KICKSPACE® 500 Duo)

Summer/Off/Winter - Fan only/off/heating options.

System Selector - Central heating/electric heating.

Fan Speed - Normal/boost.

Electric (KICKSPACE® 500E)

Summer/Off/Winter - Fan only/off/heating option.

Power Selector - 1kW or 2kW.

Fan Speed - Normal/boost.

Electric (KICKSPACE® 600E)

Summer/Winter/Output.

KICKSPACE® Performance Data

Hydronic Models

It is preferable to select the model with an output capable of maintaining the calculated heat losses of the room when operating at normal speed. This will enable the boost fan speed and the higher temperature differences to be used to greater advantage for rapid warming of the room from cold in excessive conditions.

When establishing the temperature difference, i.e. mean water to room temperature, allowance should be made for temperature drop in the system. It is the water temperature at the convector which dictates the output.

Hydronic Heating Performance Data

Model	Fan Speed	Heat Output (watts) Temperature Difference (°C)						Heat Output (Btu/h) Temperature Difference (°F)					
		40°	45°	50°	55°	60°	65°	72°	81°	90°	99°	108°	117°
500	Normal	733	815	896	976	1056	1135	2501	2781	3058	3332	3603	3873
	Boost	923	1045	1166	1289	1412	1535	3152	3565	3981	4398	4817	5238
600	Normal	880	1053	1225	1393	1560	1730	3002	3594	4179	4754	5322	5904
	Boost	1275	1453	1630	1803	1975	2150	4350	4959	5561	6154	6738	7336
800	Normal	1396	1552	1707	1860	2012	2162	4763	5295	5824	6346	6865	7377
	Boost	1738	1964	2192	2420	2649	2879	5930	6701	7479	8257	9038	9823
Floor	Normal	622	711	802	894	987	1080	2122	2426	2736	3050	3368	3685
	Boost	1035	1177	1322	1468	1615	1763	3531	4016	4511	5009	5510	6015

Heat outputs tested in accordance with BS 4856 Part 1.

Low Voltage Hydronic Heating Performance Data

Model	Fan Speed	Heat Output (watts) Temperature Difference (°C)						Heat Output (Btu/h) Temperature Difference (°F)					
		40°	45°	50°	55°	60°	65°	72°	81°	90°	99°	108°	117°
600-12V Compact	Normal	461	525	590	655	720	787	1574	1791	2011	2234	2458	2684
600-12V	Normal	880	1053	1225	1393	1560	1730	3002	3594	4179	4754	5322	5904
	Boost	1275	1453	1630	1803	1975	2150	4350	4959	5561	6154	6738	7336

Heat outputs tested in accordance with BS 4856 Part 1.

Duo (Hydronic/Electric) Heating Performance Data - Electric Mode

The unit will operate on either fan speed to provide 1kW of heating.

Duo (Hydronic/Electric) Heating Performance Data - Hydronic Mode

Model	Fan Speed	Heat Output (watts) Temperature Difference (°C)						Heat Output (Btu/h) Temperature Difference (°F)					
		40°	45°	50°	55°	60°	65°	72°	81°	90°	99°	108°	117°
500 Duo	Normal	636	734	835	938	1043	1151	2169	2505	2849	3201	3560	3926
	Boost	835	958	1083	1210	1340	1471	2847	3267	3695	4130	4572	5020

Heat outputs tested in accordance with BS 4856 Part 1.

Flow Rate: 340 ltr/h (75 gal/h).

Flow Rate Correction Factors:

455 ltr/h (100 gal/h) multiply output by 1.03.

227 ltr/h (50 gal/h) multiply output by 0.96.

113 ltr/h (25 gal/h) multiply output by 0.85.

Approximate Hydraulic Resistance

ltr/h	mm wg							kPa						
	500	600	800	Floor	600-12V Compact	600-12V	500 Duo	500	600	800	Floor	600-12V Compact	600-12V	500 Duo
455	788	1046	911	448	671	1046	652	7.7	10.3	8.9	4.4	6.6	10.3	6.4
340	488	625	544	258	454	625	380	4.8	6.1	5.3	2.5	4.5	6.1	3.7
227	231	326	258	136	262	326	204	2.3	3.2	2.5	1.3	2.6	3.2	2.0
113	82	95	82	54	101	95	68	0.8	0.9	0.8	0.5	1.0	0.9	0.7

KICKSPACE® Performance Data (continued)

Air Flow

Model	Air Flow (m³/h)		Air Flow (ft³/h)	
	Normal	Boost	Normal	Boost
500	70	90	2471	3177
600	106	138	3742	4872
800	139	210	4908	7415
Floor	76	169	2684	5968
600-12V Compact	60	N/A	2119	N/A
600-12V	106	138	3742	4872
500 Duo	70	90	2471	3117

Noise Levels

Model	Sound Pressures at 2.5m (dBA)	
	Normal	Boost
500	25.7	38.1
600	26.4	37.2
800	28.5	49.8
Floor	27.4	56.1
600-12V Compact	23.8	N/A
600-12V	29.4	39.0
500 Duo	25.7	38.1

Weight, Water Content and Motor Power

Model	Motor Power (W)	Water Content (l)	Unit Weight (kg)
500	25	0.15	5.5
600	40	0.30	5.9
800	40	0.18	5.5
Floor	28	0.07	5.5
600-12V Compact	10	0.10	5.0*
600-12V	40	0.30	7.9*
500 Duo	25	0.105	4.5

* Includes transformer

Noise levels tested in accordance with EN 23741.

Electric Models

Electric Heating Performance Data

Model	Heat Output (watts)		
	Low	Medium	High
500E	1000	N/A	2000
600E	1000	2000	3000

Air Flow

Model	Air Flow (m³/h)		Air Flow (ft³/h)	
	Low	High	Low	High
500E	70	90	2471	3177
600E	210	N/A	7560	N/A

Weight

Model	Unit Weight (kg)
500E	3.0
600E	3.5

Noise Levels

Model	Sound Pressures at 2.5m (dBA)	
	Low	High
500E	27.2	40.2
600E	38.0	N/A

Noise levels tested in accordance with EN 23741.

KICKSPACE® Remote Wall Switch (optional)

Available Finishes: White, Chrome, Brass, Brushed Stainless.
 All remote wall switches are supplied with 3 metres of cable. All models are equipped to facilitate direct wiring.

Suitable for uses with standard single gang surface or recessed mounting box (not supplied). The switch must only be used to operate a single KICKSPACE® unit.

For use on Hydronic and Hydronic-Electric (Duo) models only. Not suitable for Electric only models.

N.B: When a remote wall switch is fitted, the fan speed control switch on the KICKSPACE® facia grille becomes inoperable and must be disconnected.

KICKSPACE® Grille Colour Options

KICKSPACE® models 500, 600, 800, 600-12V Compact, 600-12V, 500 Duo and 500E are supplied with a White (RAL 9003) grille. All these models are also available in Brown (RAL 8017), Black (RAL 9011), Chrome, Brushed Stainless Steel and Aluminium. The 600E facia grille is an integral part of the product and can not be removed and is supplied with either a White or Brown grille. The floor unit model is only available with a Beige grille.

KICKSPACE® Electrical Data

All KICKSPACE® models require an electrical supply of 220-240V-50Hz. All models can be used in conjunction with a room thermostat, however it is essential that the thermostat used is capable of carrying the electrical load.

Hydronic (KICKSPACE® 500, 600 & 800)

Supplied with 2 metres of cable (0.75mm²).
Requires a supply fused at 3A.

Low Voltage Hydronic (KICKSPACE® 600-12V & 600-12V Compact)

Supplied with 2 metres of cable (0.75mm²).
Requires a supply fused at 3A.

N.B: Low voltage models comply with BS 7671 section 601 (IEE Safety Extra Low Voltage wiring regulations for bathrooms). The transformer complies with BS 3535. Where a remote switch or thermostat is used, the line voltage to both is 12 volts maximum.

Hydronic Electric (KICKSPACE® 500 Duo)

Supplied with 2 metres of cable (0.75mm²).
Requires a supply fused at 5A.

Electric (KICKSPACE® 500E & 600E)

500E supplied with 2 metres of cable (1.0mm²).
Requires a supply fused at 10A.

600E supplied with 2½ metres of cable (1.0mm²).
Requires a supply fused at 13A.

KICKSPACE® Dimensions

KICKSPACE® 500

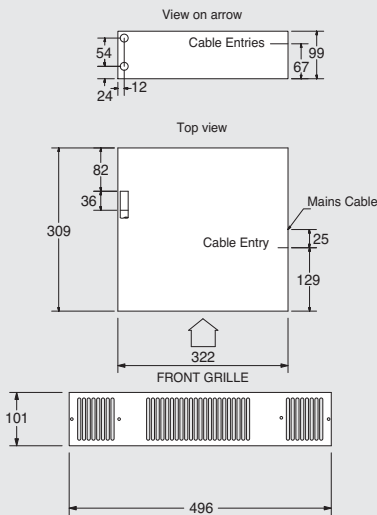

KICKSPACE® 600

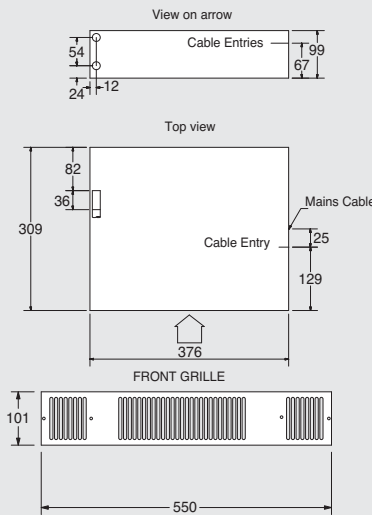

KICKSPACE® 800

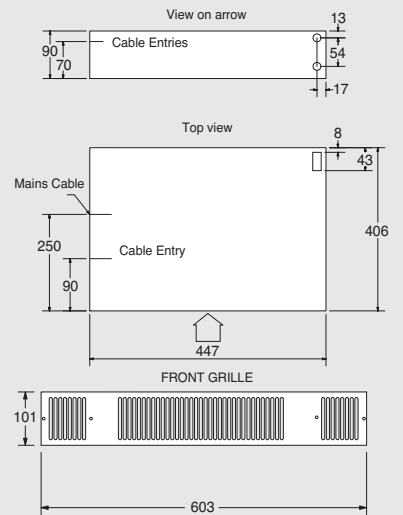

KICKSPACE® 500 Duo

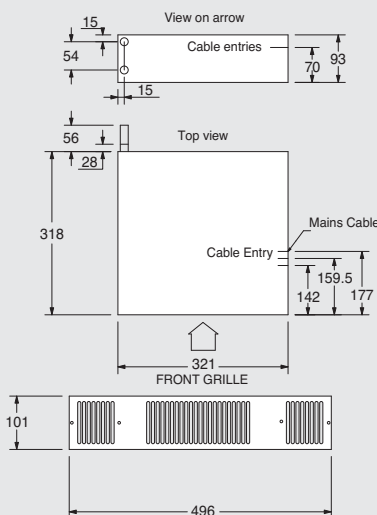

KICKSPACE® 600-12V

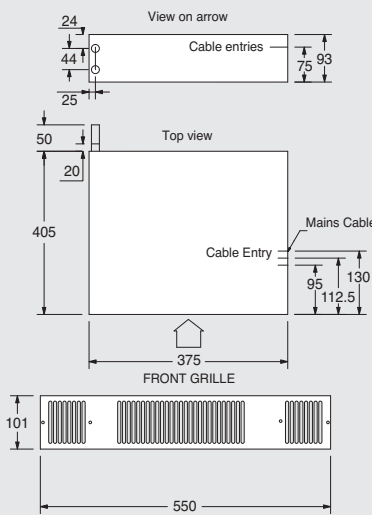

KICKSPACE® 600-12V Compact

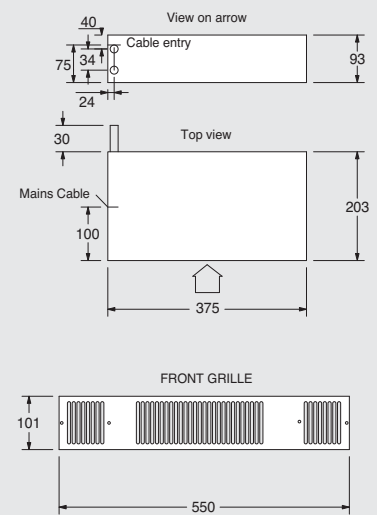

N.B: Add 4.5mm to the chassis height of the above models to allow for rubber mountings and screws.

KICKSPACE® Dimensions (continued)

KICKSPACE® 500E

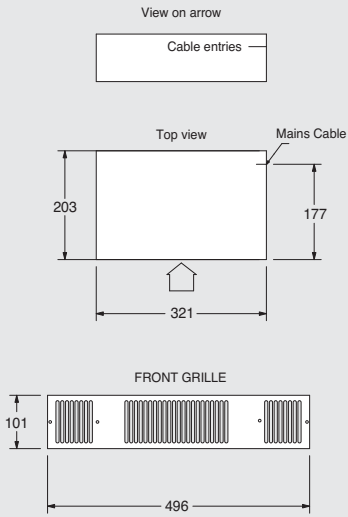

KICKSPACE® 600E

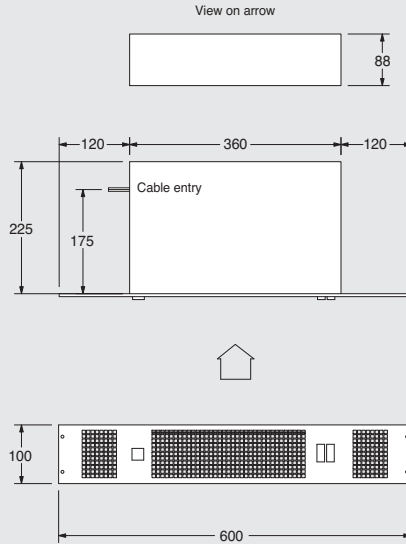

KICKSPACE® Floor

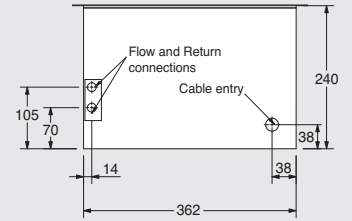

Connections

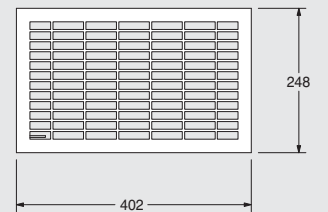

Dimensional View

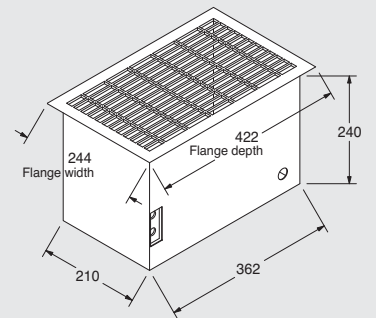

N.B: KICKSPACE® 500E: Add 4.5mm to the chassis height of the above models to allow for rubber mountings and screws.

N.B: All connections accessible from the top of unit.

KICKSPACE® Kickboard Dimensions

Option A (Excluding 500E)

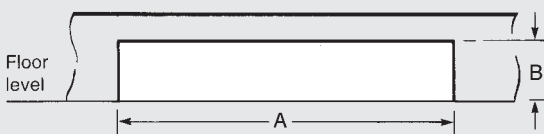

Option B (Excluding 600E)

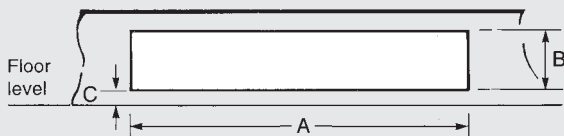

Dimensions of opening to be cut in Kickboard - KICKSPACE® 500, 600, 600-12V Compact, 600-12V, 800, 500 Duo, 500E, 600E

Model	Dimensions (mm)		
	A	B	C
500, 500 Duo, 500E	466	99	17
600, 600-12V Compact, 600-12V	520	99	17
800	575	100	17
600E	540	95	N/A

General Information for Fan Convectors

Effective Heating

To achieve the best possible results, the correct output requirement needs to be calculated. For optimal positioning and size of heat emitter please consult a qualified plumber or heating installer for advice. A heatloss manager CD can be ordered free of charge from Customer Services.

Approval & Certification

All **MYSON** fan convectors are manufactured to the requirements of BS EN ISO 9001 and the factory is certified to the environmental standard BS EN ISO 14001. All products are tested to comply with European safety standards and are CE marked as well as carrying national approval marks, where appropriate.

Performance

All **MYSON** fan convector heat outputs are tested to BS 4856 Part 1 for heating and Part 2 for cooling performance. Noise levels are independently tested by Sound Research Laboratories to EN 23741.

Packaging

All fan convectors are packed in robust cardboard packaging specially designed to ensure the product reaches you in perfect condition.

Finishing

Wall mounted fan convectors are finished with a White (RAL 9016) powder coating, while the **KICKSPACE**[®] grilles are available in White (supplied with the unit), Brown, Black, Brushed Stainless Steel, Chrome and Aluminium.

Warranty

MYSON fan convectors carry a 2 year parts and labour warranty.

Accessories

At **MYSON** we take care of every detail and there is a variety of accessories available for the fan convector range of products, including wall switches and **KICKSPACE**[®] fascia grilles. For further details, please consult the technical section of this brochure.